



## Power Systems

1400 East South Blvd.  
Montgomery, AL 36116  
(334) 286-8551 • (334) 286-8018

# Service Information Letter

The technical content of this letter is FAA Approved

Letter No. A-117

Issue Date: Nov. 28, 2006

## GENERAL RECOMMENDATIONS FOR TH08A SERIES TURBOCHARGER HANDLING

### INTRODUCTION:

It has come to our attention that a condition exists where the turbine wheel, shaft and components may experience damage due to rough or improper handling of the TH08A series of turbochargers. This family of turbochargers is unique in that the turbine wheel assembly end cap extends beyond the turbine housing and the turbine outlet wall dimensions. This exposes the turbine wheel assembly to potential loads being placed on the end of the turbine wheel during any process where the turbocharger is placed on the turbine side during assembly or other maintenance activity. The turbine outlet walls on most turbochargers provide protection against pressures or loads being placed on the turbine wheel assembly. Poor packaging for storage or shipment may also create damage which in most cases remain hidden. While this damage is not serious and generally results only in increased expense at overhaul, serious damage may occur should the turbocharger be dropped or placed on the turbine wheel end.

This Service Information letter is intended to provide general recommendations for the handling of the TH08A Series turbochargers. This information supplements any recommendations or requirements of the aircraft or rotorcraft manufacturer and should be incorporated into any scheduled or unscheduled maintenance activity.

### COMPLIANCE:

Immediately upon the start of any maintenance activity involving removal, installation, repair, overhaul, storage or shipment of any TH08A Series turbocharger

### EFFECTIVITY:

Any aircraft, rotorcraft, or engine utilizing Kelly Aerospace Power Systems TH08A Series turbochargers as indicated on Table 1. (Including those units made by Garrett/AirResearch, AlliedSignal, Garrett/Honeywell, and Consolidated Fuel Systems, Inc.)

### PROCEDURE:

#### Note:

The maintenance recommendations in this Service Information Letter apply to the TH08A Series turbocharger only. However, it is good practice to observe these general precautions while working on any turbocharger.

1. If the turbocharger is being stored or shipped in a box the following should be observed:
  - a. Because the turbine wheel end cap stands out higher than the housing or turbine outlet walls, never place the turbocharger on a shelf or flat surface where it rests on the turbine wheel. (See Fig. 1.)
  - b. If storing the turbocharger in its original shipping container, first assure that the unit is packaged well with all openings capped and with the turbine side facing up.
  - c. If the turbocharger is to be shipped, whether in its original shipping container or repackaged, make sure that the turbine side is protected against shock by inserting a cardboard shock absorber. Construct this using a cardboard piece the size of the box, 1 inch thick with a 4.5 inch hole cut in the appropriate area to allow the turbine outlet to rest in. (See Fig. 2.)

## **PROCEDURE: (cont'd)**

2. If the turbocharger is being disassembled, assembled, overhauled or repaired, the following should be observed:
  - a. Because the turbine wheel end cap stands out higher than the housing or turbine outlet walls, never place the turbocharger on a table or flat surface where it rests on the turbine wheel end cap. (See Fig. 1.)
  - b. Never drop the turbocharger, especially on the turbine end. *If this occurs or it is suspected that it has occurred or if damage on the end of the turbine wheel is evident, the turbocharger must be sent to a certified repair facility to be disassembled, inspected and repaired prior to any return to service.*
  - c. Any time the turbocharger is being worked on, it should be placed in a suitable fixture where the turbine wheel end cap cannot support the turbocharger. A sample fixture is shown in Fig. 3. It should be made from hardwood or equivalent material to the rough dimensions shown.
3. If the turbocharger is being removed or installed on an aircraft, rotorcraft, or engine, the following should be observed:
  - a. Because the turbine wheel end cap stands out higher than the housing or turbine outlet walls, never place the turbocharger on a table, toolbox, or flat surface where it rests on the turbine wheel end cap. (See Fig. 1.)
  - b. If removing the turbocharger, place a tag on the turbocharger that states, "DO NOT SIT OR REST TURBOCHARGER WITH TURBINE END ON A SURFACE, FACE TURBINE END UP".
  - c. If installing the turbocharger, use the fixture shown in Fig. 3 or assure that the unit is not placed on the turbine wheel end cap. Remove tag if attached.

## **MATERIALS REQUIRED:**

Locally obtained cardboard, boxes and hardwood.

## **PARTS AVAILABILITY:**

Not applicable

## **WARRANTY STATEMENT:**

The sole warranty applicable to this service publication is related to the terms and conditions of a valid original Limited Warranty Policy for a new, rebuilt, or overhauled turbocharger as delivered from Kelly Aerospace Power Systems through its authorized distributors. This publication does not imply or state any responsibility for the workmanship of any person or entity performing work or maintenance on the turbocharger, engine, aircraft, or rotorcraft. Unless specified by Kelly Aerospace Power Systems in writing, use of any non-Kelly part or component is prohibited and will void any outstanding or remaining warranty.

## **CONTACT INFORMATION:**

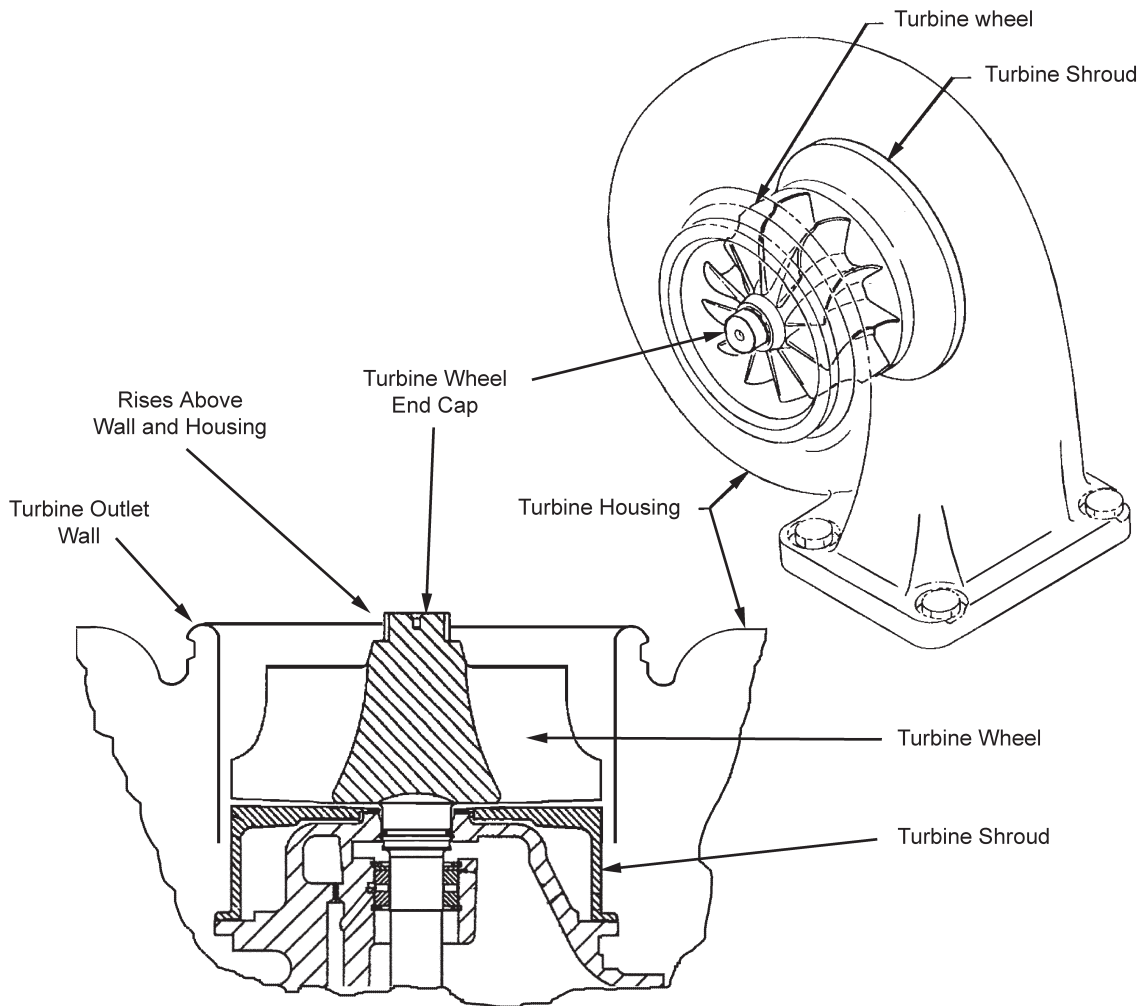
If you have any questions concerning the instructions in this Service Information Letter, please contact Kelly Aerospace Power Systems Technical Support at 888-461-6077.

Questions concerning the engine, aircraft, or rotorcraft service or operation must be forwarded to the applicable manufacturer of that product.

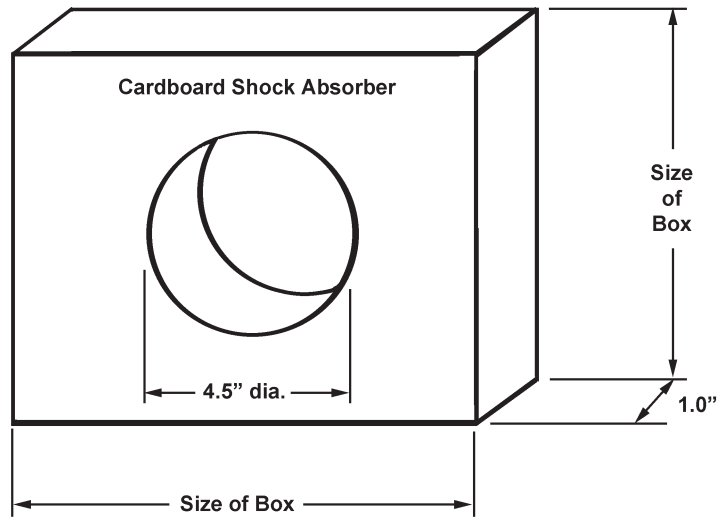
**TABLE 1**

<b>TH08A Series Turbochargers</b>	
407810-0001	465680-0003
407810-0003	465680-0004
409170-0001	465680-0005
409680-0001	465680-0006
409680-0011	465930-0001
465680-0001	465930-0002

*Note: Turbochargers which are not new may incorporate a "9" after the dash.  
(example 407810-9001)*

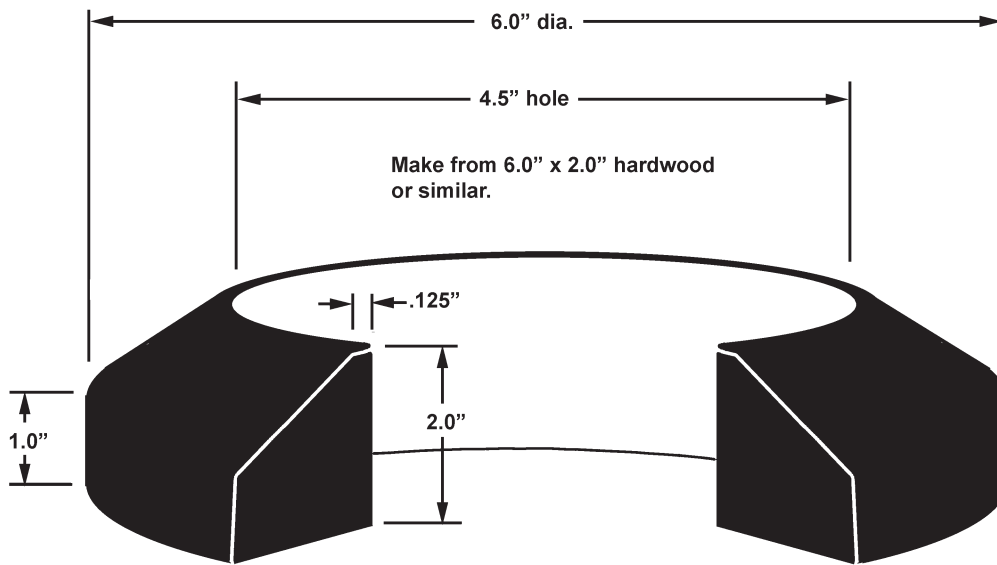


**Fig. 1**



**Fig. 2**

To use, place the turbine outlet in the hole with the turbine housing resting on the cone.



*Section removed for clarity.*

**Fig. 3**